

# Dust Collection System - DCA200

Suits Triton Workcentres & Series 2000 Router Tables

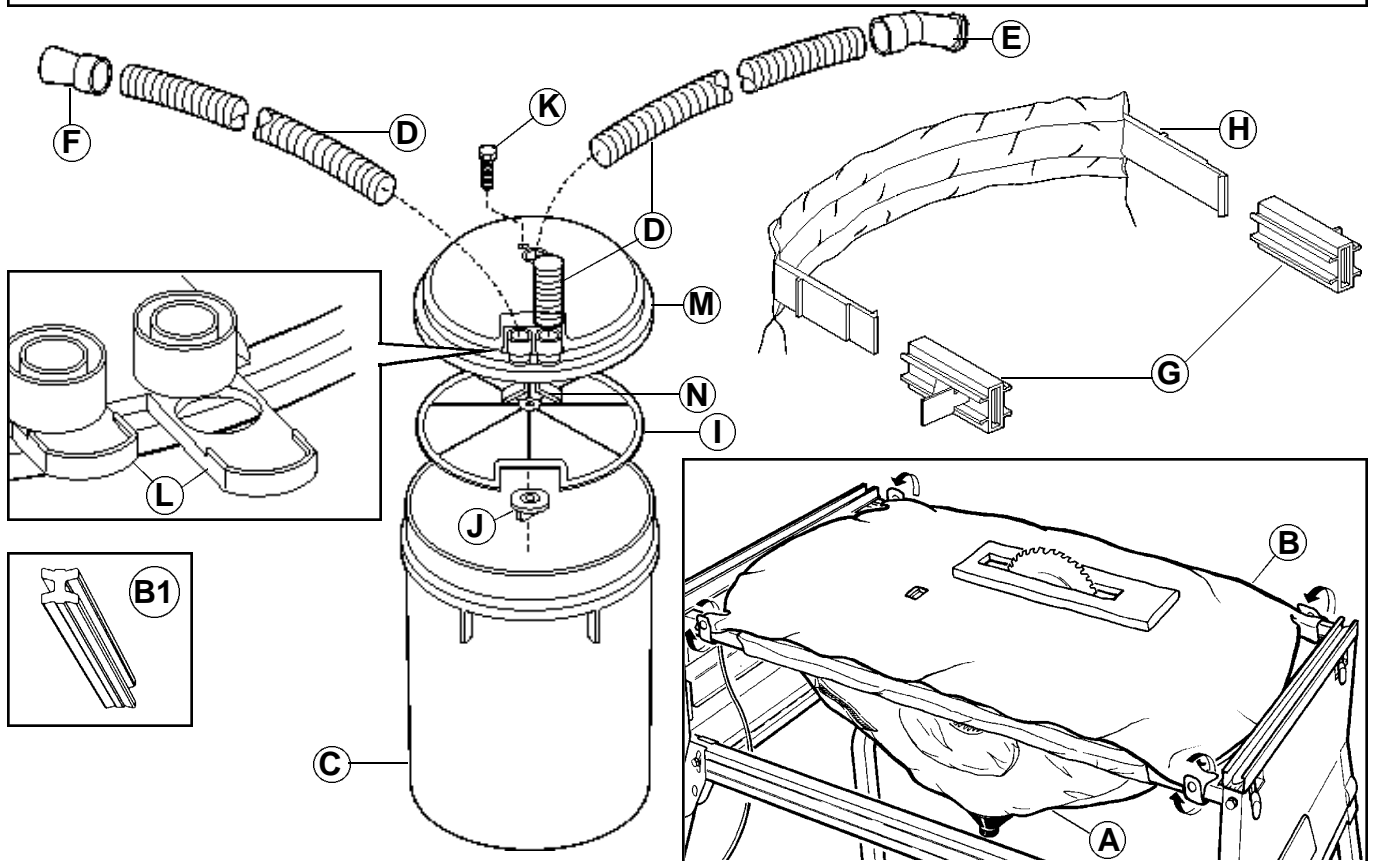

Diag. Ref.	Part No.	Description	Qty Supplied as Spare Part	Comments
-	CPA104	Packing Bag (plastic)	1	
-	PUA291	Assembly Instructions	1	
A	DCA007	Dust Bag Assembly	1	
B	DCA045	Sealing Flap & Foam Assembly	1	
B1	DCA042	Saw Slot Infill Plug	1	Suits Series 2000 Workcentre
C	DCA018	Canister (20 litre)	1	No fittings
D	DCA026	Hose Replacement (2.25m)	1	Can be cut to required length
E	CMA033	Bayonet Hose Adaptor	1	
F	CMA032	Tapered Hose Nozzle	1	
G	DCA048	Dust Bag Clips	4	
H	DCA049	Dust Bag Hoops	2	
I	DCA015	Filter	1	
J	CMA040	Round Knob (6mm)	1	
K	-	6mm x 25mm Hex Bolt	1	Not supplied as spare
L	DCA013	Slide Valve	2	
M	DCA011	Lid	1	No filter or slide valves
N	DCA014	Deflector Valve	1	

## Specifications:

**Packed weight:** 2.32kg  
**Vacuum Hose:** I.D. 32mm

**Dimensions:** 325 x 325 x 470mm  
**Lengths:** Short - 75mm    Medium - 750mm    Long - 2250mm

**Volume:** 0.049m<sup>3</sup>